



Australian Government
Inspector-General of Biosecurity

Assurance review for arrangements to import live lumpy skin disease virus to CSIRO's Australian Centre for Disease Preparedness

REVIEW REPORT NO. 2022-23/02



© Commonwealth of Australia 2022

Ownership of intellectual property rights

Unless otherwise noted, copyright (and any other intellectual property rights) in this publication is owned by the Commonwealth of Australia (referred to as the Commonwealth).

Creative Commons licence

All material in this publication is licensed under a [Creative Commons Attribution 4.0 International Licence](#) save for content supplied by third parties, logos and the Commonwealth Coat of Arms.

Inquiries about the licence and any use of this document should be emailed to copyright@awe.gov.au



Cataloguing data

This publication (and any material sourced from it) should be attributed as: Inspector-General of Biosecurity 2022, *Assurance review for arrangements to import live lumpy skin disease virus to CSIRO's Australian Centre for Disease Preparedness*, Department of Agriculture, Fisheries and Forestry, Canberra, [July], 2022–23/02.

ISBN 978-1-76003-545-7

This publication is available at igb.gov.au.

Inspector-General of Biosecurity
c/- Department of Agriculture, Fisheries and Forestry
GPO Box 858, Canberra ACT 2601
Email InspGenBiosecurity@agriculture.gov.au
Web igb.gov.au

The Australian Government represented by the Inspector-General of Biosecurity, has exercised due care and skill in preparing and compiling the information and data in this publication. Notwithstanding, the Inspector-General of Biosecurity, the Australian Government's employees and advisers disclaim all liability, including for negligence and for any loss, damage, injury, expense or cost incurred by any person as a result of accessing, using or relying on any of the information or data in this publication to the maximum extent permitted by law.

Acknowledgements

Thanks to Dr Nazia Nisar, Ms Clare Hamilton and Ms Julia Darcy for supporting and drafting this review. The Inspector-General gratefully acknowledges cooperation and advice of the Australian Government Department of Agriculture, Fisheries and Forestry and CSIRO Australian Centre for Disease Preparedness.

Image credits

Photographs courtesy of Department of Agriculture, Fisheries and Forestry.

Contents

Executive summary	1
Recommendations	3
Assessment summary	4
Overview	5
Review approach	6
Assessment of LSDV import risk assessment, approval and logistics processes and risk mitigation measures	8
Introduction	5
1. Department's LSD capability	9
1.1 Technical knowledge of LSD threat to Australia	9
1.2 Demonstrated international collaboration and leadership	9
1.3 Understanding of evolving offshore LSD distribution and threat to Australia	10
1.4 Effective national LSD partnering	11
1.5 Effective consultation with Australian industries	11
2.1 Government policy decision in place to support potential LSDV import	13
2. Policy approval for LSDV import	13
3. Department's technical and regulatory expertise for disease agent risk assessment	14
3.1 Technical knowledge on Australian research on exotic animal diseases	14
3.2 International animal biosecurity science and risk assessment network	15
3.3 International biological agent transport and import expertise	16
3.4 Effective regulatory and technical partnering with CSIRO	17
3.5 Track record of effective import permit assessment and regulation for disease agents	18
4. Basis for import permit approval	19
4.1 ACDP is a capable LSDV recipient	19
4.2 Relevant regulations are in place for import, transport, storage and use and safe disposal of LSDV by the ACDP	20
4.3 LSDV is an acceptable risk for use at the ACDP	21
4.4 LSDV is coming from a reputable source capable of providing pure LSDV samples	22
4.5 Biological samples logistics, security and safety risks can be effectively mitigated	22
4.6 ACDP receipt and security processes for LSDV meet required standards	23
5. Incident response arrangements in place	24
5.1 Incident response arrangements for Melbourne Airport, transport, and ACDP Geelong	24
6. Ongoing accountability	26
6.1 Ongoing assurance review and reporting arrangements	26
7. Conclusion	27
8. Glossary	28

9. References	30
10. Appendix A: Department’s consultation with Australian industry stakeholders	34
11. Agency response	44

Tables

Table 1 Assessment of lumpy skin disease virus import risk assessment, approval and logistics processes and risk mitigation measures	4
--	---

Executive summary

This assurance review examined arrangements for the import of live lumpy skin disease virus (LSDV) into CSIRO's Australian Centre for Disease Preparedness (ACDP) facility.

Lumpy skin disease (LSD) is a viral disease of cattle and water buffalo that causes an acute disease with fever, depression, and characteristic skin nodules. It has a relatively low mortality, but it can result in animal welfare issues and significant production losses. LSD does not pose a risk to human health.

LSD was originally limited to Africa, but its global distribution is increasing the risk to Australia. In 2021 the disease was confirmed in Vietnam, Thailand and Malaysia and in March 2022 it was officially reported by Indonesia on the island of Sumatra.

In April 2022, the former Minister for Agriculture requested that the Inspector-General undertake an assurance review for the import of live lumpy skin disease virus (LSDV) and vaccine/s. Having considered a range of matters regarding the potential review, the Inspector-General agreed to complete the review. On 21 April 2022, the Inspector-General advised the Director of Biosecurity that the Inspector-General's planned review program had been updated, consistent with Sections 90(3) and 91(3) of the Biosecurity Regulation 2016.

This review included potential importation of live LSDV into CSIRO's ACDP facility. The review did not cover the potential future importation of vaccines to be used for an emergency response to an LSD incursion to protect Australia's susceptible animal industries.

This review has confirmed that:

- The ACDP, a world-class and globally connected high-security containment facility at Geelong, is well equipped to safely receive and store LSDV and conduct research, diagnostic test development and vaccine testing using the virus.
- The department is very well qualified to assess biosecurity risks associated with import of LSDV into Australia to the high-security ACDP facility.
- Well-established international standards, processes and service providers will be involved for the sourcing, consignment protection, transport and receipt arrangements for the import of LSDV.
- The department is well equipped to carry out its regulatory responsibilities for the issuing of an import permit to the ACDP and managing its regulatory responsibilities regarding the import consignments and ACDP compliance with requirements of the approved arrangement class 5.3 biocontainment level 3 (BC3) laboratories.

Recommendations

- Biosecurity partners and directly relevant stakeholders are well informed about both the threat that LSD poses to Australia and measures that the department and the ACDP are advancing to ensure they are fully prepared to respond rapidly and effectively to any incursion into Australia of LSD.

The Inspector-General is satisfied that arrangements in place at the ACDP facility, within the department and for the logistics chain for import of LSDV are appropriate to mitigate risks associated with the planned import of LSDV to the ACDP facility.

The Inspector-General recommends to the Director of Biosecurity that the department should carry out its normal functions for risk assessment, regulatory approval, monitoring and compliance management for biological agent importation in regard to the import of LSDV to the ACDP facility.

Recommendations

Recommendation 1

The Director of Biosecurity should note that the Inspector-General has reviewed a suite of matters relevant to the potential import of lumpy skin disease virus to the CSIRO Australian Centre for Disease Preparedness and found no reason why the Director of Biosecurity or his delegate should not approve the ACDP application for an import permit.

Recommendation 2

The Director of Biosecurity should note that the Inspector-General has found no basis on which to recommend any additional risk mitigation measures beyond those the department has already stipulated to be applied to the import of lumpy skin disease virus to the CSIRO Australian Centre for Disease Preparedness.



Rob Delane

Inspector-General of Biosecurity

08 July 2022

Assessment summary

Table 1 Assessment of lumpy skin disease virus import risk assessment, approval and logistics processes and risk mitigation measures

Measures in place	IGB assessment
1. Department's LSD capability 1.1) Technical knowledge of LSD threat to Australia 1.2) Demonstrated international collaboration and leadership 1.3) Understanding of evolving offshore LSD distribution and threat to Australia 1.4) Effective national LSD partnering 1.5) Effective consultation with Australian industries.	Optimal
2. Policy approval for LSDV import 2.1) Government policy decision in place to support potential LSDV import.	Optimal
3. Department's technical and regulatory expertise for disease agent risk assessment and import approval 3.1) Technical knowledge on Australian research on exotic animal diseases 3.2) International animal biosecurity science and risk assessment network 3.3) International biological agent transport and import expertise 3.4) Effective regulatory and technical partnering with CSIRO 3.5) Track record of effective import permit assessment and regulation for disease agents.	Optimal
4. Basis for import permit approval 4.1) ACDP is a capable LSDV recipient 4.2) Relevant regulations are in place for import, transport, storage and use and safe disposal of LSDV by the ACDP 4.3) LSDV is an acceptable risk for use at the ACDP 4.4) LSDV is coming from a reputable source capable of providing pure LSDV samples 4.5) Biological sample logistics, security and safety risks can be effectively mitigated 4.6) ACDP receipt and security processes for LSDV meet required standards.	Optimal
5. Incident response arrangement in place 5.1) Incident response arrangements for Melbourne Airport, transport and ACDP Geelong.	Optimal
6. Ongoing accountability 6.1) Ongoing assurance review and reporting arrangements.	Optimal

Note: The Inspector-General of Biosecurity assessment rating for each measure, where not otherwise specified, integrates the ratings for sub-items. Ratings may be 'Optimal', 'Marginal' or 'Unsatisfactory'.

Introduction

Overview

This assurance review examined arrangements for the import of live lumpy skin disease virus (LSDV) into CSIRO's Australian Centre for Disease Preparedness (ACDP) facility.

Lumpy skin disease (LSD) is a viral disease of cattle and water buffalo that causes an acute disease with fever, depression, and characteristic skin nodules. It has relatively low mortality, but it can result in animal welfare issues and significant production losses. LSDV is not generally considered to be zoonotic, and it does not pose a risk to human health (OIE, 2021).

LSD was originally limited to Africa. However, the global distribution of LSD is increasing the risk to Australia. Since 2019 the disease has spread through China and South-East Asia. In 2021 the disease was confirmed in Vietnam, Thailand and Malaysia. In March 2022, it was officially reported by Indonesia on the island of Sumatra.

LSDV is a member of the genus *Capripoxvirus*, subfamily *Chordopoxvirinae*, family Poxviridae. It is a large, complex virus containing a linear double-stranded DNA genome (King et al., 2011). Poxviruses are stable in the environment and retain infectivity for months under ideal conditions.

The disease is spread primarily by biting insects such as certain species of flies, mosquitoes and possibly ticks. There is strong evidence for the significant role of blood-sucking arthropods in the transmission of LSDV and windborne dispersal of infected arthropod vectors (for example, Klausner et al., 2017; Sohler et al., 2019; Issimov et al., 2020).

It has been reported that the disease can also be spread in the absence of arthropod vectors (Aleksandr et al., 2020). It has been argued that spread may also occur by fomites through such things as contaminated equipment and in some cases directly from animal to animal.

If LSD were to occur in Australia, it would have significant consequences for our beef, water buffalo, and dairy cattle industries. An LSD incursion could result in severe economic losses for Australia's meat processing sector. There would also be substantial trade impacts if Australia were no longer recognised as being free from LSD. If wild buffalo populations and cattle in northern Australia's extensive rangelands were exposed to LSD, reservoirs of the virus could establish. If this were to occur, eradication would be extremely difficult.

Australia's strict livestock importing protocols are designed to counter the risk of exotic disease incursions. Returning livestock vessels are also managed by the department's biosecurity officers. Border requirements are in place for incoming air and sea passengers, imported cargo and mail items to ensure the biosecurity risks are managed at the border.

Early detection is essential for successful control and eradication of the disease. To ensure this can happen, we need a highly reliable rapid testing capability. The ACDP is the national reference laboratory for new and emerging diseases, diagnostic test validation, science and laboratory biological risk. It requires access to live LSDV to improve national diagnostic capacity for LSD. This will ensure that Australia is best placed to detect the presence of LSDV early and rapidly respond to any incursion.

In southern Europe, vaccination has been used to effectively control LSD outbreaks. Only live-attenuated vaccines are commercially available for vaccination against LSD. Currently, most commercially available vaccines against LSD are live-attenuated vaccines based on an LSDV strain, sheeppox virus, or goatpox virus (Tuppurainen et al., 2021). There is currently no LSD vaccine approved for use in Australia. Potential candidate live vaccines for LSD will need to be safely imported into Australia for testing at the ACDP, Geelong facility.

As defined in the Biosecurity (Conditionally Non-prohibited Goods) Determination 2021 under the *Biosecurity Act 2015*, an infectious agent includes any of the following (whether naturally occurring or synthetically created): a virus, a prion, a plasmid, a viroid, or a thing that is a part of an infectious agent. The department is responsible for regulating the import of infectious agents (DAWE, 2022a).

Importation of infectious agents into Australia may be permitted under specific circumstances. Before the import of any infectious agent is permitted, a risk assessment must be carried out. This assessment will determine the potential consequences and the appropriate risk management to prevent the establishment of the agent in Australia, in accordance with our appropriate level of protection (ALOP).

Import applications for non-live (or inactivated) infectious agents, or a part of an infectious agent, also require a risk assessment to be undertaken to determine whether the inactivation technique will be sufficient to manage biosecurity risks.

The level of biosecurity risk associated with importing a live infectious agent will vary depending on the nature of the agent. Infectious agents such as LSDV are assessed as high risk.

The department oversees and completes several compulsory steps before a live infectious agent is permitted to be imported into Australia. These steps are normally triggered when an importer applies for a biosecurity import permit to import an infectious agent. The ACDP is the applicant for importation of LSDV to the ACDP, Geelong facility.

Review approach

Authority of the Inspector-General of Biosecurity

The Inspector-General of Biosecurity is an independent statutory role under the *Biosecurity Act 2015*. The federal Agriculture Minister appoints the Inspector-General to conduct general reviews of the performance of functions and the exercise of powers by the Director of Biosecurity and senior biosecurity officials. The Secretary of the Department of Agriculture, Fisheries and Forestry is the Director of Biosecurity.

The Inspector-General is independent of the Minister and the Director of Biosecurity but may consider the Minister's request for a review and seek immediate action from the Director of Biosecurity, senior biosecurity officials and the Minister to protect and enhance the integrity of Australia's biosecurity system.

For a review, the Inspector-General requests data and information from department officials, both in writing and verbally. The Inspector-General must publish a report on each review conducted under the Biosecurity Act.

The Inspector-General's scope does not extend to Australia's national biosecurity policies, international trade issues and market access opportunities.

Ministerial request for review

In April 2022, the former Minister for Agriculture requested the Inspector-General to undertake an assurance review for the import of live LSDV and vaccine/s (Littleproud, 2022).

Having considered a range of matters regarding the potential review, the Inspector-General agreed to complete the review. On 21 April 2022, the Inspector-General advised the Director of Biosecurity that the Inspector-General's planned review program had been updated, consistent with sections 90(3) and 91(3) of the Biosecurity Regulation 2016. The revised Review Program was published on the Inspector-General's website (IGB, 2022).

Scope

This current review will include potential importation of live LSDV or vaccine into the ACDP for the purpose of developing diagnostic tests, research or testing the efficacy and safety of that vaccine.

The review will not consider the adequacy of the department's assessment of the threat posed by LSD to the susceptible animal industries of Australia.

The review will not cover the potential future importation of vaccines to be used for an emergency response to a LSD incursion. Such a review may be considered by the incoming Inspector-General, whose term begins on 25 July 2022.

The review will focus on:

- the adequacy and rigour of risk assessment for the import of live virus pure culture and/or vaccines containing live virus into Australia's secure animal biosecurity facility at the ACDP, Geelong
- the adequacy of the regulatory import approval process for LSD live virus consignments
- the adequacy of measures to mitigate risks during the import logistics for LSD live virus consignments
- the adequacy of secure air freight consignment transport from Melbourne Airport and receipt into secure facilities at the ACDP
- the adequacy of the department's internal assurance processes and external compliance activities relevant to LSD live virus importation.

The review will note, but not evaluate, the adequacy of the domestic stakeholder consultation completed by the department.

Out of scope

This review will not examine:

- the effectiveness of the department's controls to manage animal biosecurity risks associated with cargo, mail and passenger movements into Australia
- policy and activities that are the responsibility of stakeholders other than the department – including state and territory agencies or governments, individuals and biosecurity industry participants
- policies and procedures of the ACDP other than those specifically relevant to LSD
- importation of LSD vaccines for use in Australian animals in response to an LSD incursion into Australia
- commercial considerations.

Process

The review included the following steps:

- In preparation for the review, a workplan and preliminary information and data request was finalised in consultation with biosecurity animal senior executives.
- The department identified key personnel to provide information and advice and be interviewed by the Inspector-General and review team.
- Consultation meetings were held with staff in relevant areas in the department. Before the meetings, interviewees were provided with the workplan and preliminary information and data request to ensure shared understanding of the purpose, scope, process and accountabilities for the review.
- Where the review of information and the initial consultation meetings led to further questions, these were followed up in secondary information and data requests.
- The Inspector-General was given a comprehensive tour of the ACDP secure facilities and provided with detailed briefings on its operation, receipt and disposal of biological samples, and international collaboration.

This report has been prepared with a structure that addresses the key risk areas related to the import of LSDV into Australia and its transport into secure handling within the ACDP, Geelong facility. The structure of the report aligns closely with the measures listed in the Assessment Summary section of this report.

Assessment of LSDV import risk assessment, approval and logistics processes and risk mitigation measures

The Inspector-General has reviewed a number of international publications on LSD, including EFSA (2015), Namazi and Khodakaram Tafti (2021) and Tuppurainen et al., (2021). However, the Inspector-General has largely drawn from a comprehensive scientific review completed by the department (DAWE, 2022b) as part of its background work in assessing the import application from the ACDP and other reference documentation available from the department and the ACDP.

In consultation with the department, the Inspector-General defined 19 assessment criteria that would provide focus to the assessment of capabilities and arrangements for the import of LSDV. The 19 'measures in place' are shown in Table 1. The Inspector-General considers that assessment of capability, standards and readiness against each of the 19 criteria is an appropriate and practical way of 'assessing the department and ACDP's capability to address risks associated with LSDV import to ACDP facility'.

1. Department's LSD capability

1.1 Technical knowledge of LSD threat to Australia

The department's staff have demonstrated high levels of technical knowledge of the threat to Australia posed by LSD. They have analysed relevant peer reviewed scientific information on LSD status, epidemiology, host and vector distribution, disease symptoms and diagnosis, and prevention and treatment. The department has also consulted with industries and state and territory governments.

The department has designed a biosecurity risk assessment framework (Biosecurity Import Risk Analysis Guidelines 2016 (BIRA guidelines)) to conduct risk analyses (DAWR, 2016a). The Inspector-General notes that the department's LSD risk assessment process is consistent with BIRA guidelines and the standards described in Chapter 2.1. of the World Organisation for Animal Health (WOAH) code, Sanitary and Phytosanitary (SPS) Agreements and other international obligations.

The department's LSD specific risk assessment of the processes and facilities at the ACDP involves:

- assessing all possible pathways for live LSDV to escape from the ACDP
- determining the likelihood of any inadvertent contamination of imported LSDV samples with other pathogens of biosecurity concern
- development of biosecurity import conditions and implementation of risk management measures under the Biosecurity Act to meet Australia's ALOP.

The Inspector-General notes that the department's technical knowledge and scientific expertise in assessing the LSD threat to Australia are appropriate to assess, plan and regulate the mitigation of the biosecurity risk of importing live LSDV into Australia.

1.2 Demonstrated international collaboration and leadership

The Inspector-General notes Australia's active engagement with both the WOA (formally Office International des Epizooties (OIE)), through the Office of the Australian Chief Veterinary Officer (ACVO) (who has recently finished his term as WOA President), and the Food and Agriculture Organization of the United Nations (FAO). Australia is also a member of the Quads Animal Health Alliance (Quads), which aims to strategically

participate and provide leadership through the WOA and explores mutually important issues on animal health and trade.

The Inspector-General notes that the department plays important roles in capacity-building initiatives in neighbouring countries Indonesia, Timor-Leste and Papua New Guinea (PNG), funded by the Australian Government. This includes:

- Australian Indonesian Health Security Partnership (AIHSP) to support containment activities for the latest LSDV outbreak in Indonesia. AIHSP is the primary mechanism through which the Australian Government is supporting Indonesia to contain the latest LSDV outbreak. AIHSP has built on the earlier accomplishments of the Australian Indonesia Partnership for Emerging Infectious Diseases (AIP-EID) between 2011 and 2018. The AIP-EID helped build Indonesia's emergency disease management response, animal health information system, disease surveillance, and veterinary services
- additional Australian development programs the department cooperates with, which may also play a role in the Indonesian LSD outbreak response as it progresses. These include the Indonesia Australia Red Meat and Cattle Partnership, the Australia Indonesia Partnership on Promoting Rural Incomes through Support for Markets in Agriculture, and the Australian Centre for International Agricultural Research
- the department's engagement with the FAO Indonesia country office to coordinate bilateral and international efforts in support of Indonesia's LSDV outbreak response
- supporting Timor-Leste and PNG with field surveillance, preparedness and outbreak response. LSDV has not been reported from either PNG or Timor-Leste. However, given they share a land border with Indonesia, they are at significant risk of LSDV incursion if the disease continues to spread through the Indonesian archipelago.

The department has engaged in research projects with its international counterparts, including:

- its Thailand counterpart, to better understand the potential role of biting midges as LSDV vectors
- the Pirbright Institute, United Kingdom, to identify and characterise different strains of LSDV and to improve diagnostic tests and vaccines.

The Inspector-General notes that the department is well connected with international expert organisations and individuals that provide it with access to world-leading contemporary knowledge on the biosecurity threat posed by LSD and the technical expertise regarding LSDV diagnosis, research and vaccine development.

1.3 Understanding of evolving offshore LSD distribution and threat to Australia

The Inspector-General notes that the department's biosecurity animal staff have extensive connections with international experts that provide valuable intelligence on LSD threat; status of LSD outbreaks globally; and the available measures applied for prevention, control and eradication of the disease. The department has engaged expert consultants to assess the biosecurity risk pathways for LSDV and its vectors into Timor-Leste and northern Australia.

The department continually monitors LSD spread in LSD-affected regions globally and supports Indonesia's LSD outbreak response. In March 2022 the ACVO visited Indonesia to meet with representatives of the Indonesian Government to discuss the outbreak and offer assistance with their LSD outbreak response. Department staff also visited Timor-

Leste and PNG in April and June 2022 respectively to discuss LSD awareness planning, diagnostics and outbreak response.

The department is currently completing strategic snapshots that will help provide early warning assessment of emerging or changing biosecurity threats associated with specific commodities, trade routes and pests and diseases.

The Inspector-General notes that the department is well connected with regional counterparts and well positioned to monitor the urgency for development of world-class LSDV diagnostics and LSDV vaccine testing.

1.4 Effective national LSD partnering

On 11 May 2022, the Inspector-General had the opportunity to participate in the Animal Health Committee (AHC) meeting 41 (AHC41), held in Darwin, Northern Territory. The AHC includes the Chief Veterinary Officers (CVOs) from the Australian Government and state and territory governments. It takes expert advice from a diverse range of animal biosecurity experts, including the ACDP.

The AHC had earlier received information about the process to assess and potentially import LSDV for secure research at the ACDP, including through a briefing from the department and the ACDP on 20 April 2022 and 2 out-of-session papers.

The Inspector-General sought feedback from AHC members on whether they support the proposed importation of LSDV and if they have any questions or concerns. AHC did not raise any significant concerns and supported the decision to import LSDV into Australia.

The Inspector-General notes that the department is working closely with relevant Australian Government agencies, as well as state and territory government agencies and industry organisations, on the development and implementation of a comprehensive National LSD Action Plan (DAWE, 2022c). The plan's coverage includes international engagement, border biosecurity and trade, awareness and communication, research and innovation, surveillance, diagnostic capacity, preparedness, and resilience and recovery. There are also several surveillance programs specific to northern Australia, such as the Northern Australia Quarantine Strategy (NAQS) and the Northern Australia Biosecurity Surveillance Network (NABSnet) (DAWE, 2022c).

The department is also working with the ACDP and the Australian Pesticides and Veterinary Medicines Authority (APVMA) on the development of targeted biosecurity import permits to facilitate diagnostic and proficiency testing capability for state and territory laboratories and emergency supplies of LSD vaccines in the event of an outbreak in Australia.

The Inspector-General notes that the department continues to work closely and practically on LSD with counterparts from all Australian jurisdictions, the ACDP and other relevant biosecurity organisations.

1.5 Effective consultation with Australian industries

The Inspector-General resolved to not consult directly with industry organisations that are direct stakeholders in the threat of LSD to Australia, and potential import of LSDV to the ACDP, as the department and state and territory departments (represented on AHC) have and will continue to consult with relevant national and state and territory industry representatives.

The department has written to all major animal industry stakeholder organisations relevant to LSD and has provided detailed briefing information about aspects of the potential import of LSDV to the ACDP (see Appendix A). The department has also proactively engaged with industry on this issue through a range of communications for peak bodies, veterinarians, livestock producers and those involved in the supply chain. Communications have included webinars, industry round tables and participation at industry conferences (for example, the Northern Territory Cattlemen's Association Conference, Cattle Council of Australia and the Australian Livestock Exporters' Council).

Following the initial outbreak of LSDV in Indonesia, the department issued a series of targeted communications to vessel masters and shipping agents to ensure any returning livestock vessels were compliant with Australia's disinfection and disinsection requirements. Biosecurity import permit holders and the department's Biologicals Consultative Committee were issued with targeted information, including a formal letter, an Import Industry Advice Notice, and an alert via the department's Biosecurity Import Conditions (BICON) system (DAWE, 2022d; DAWE, 2022e). A range of communications materials have been developed and shared through social media channels and the department's website to raise community awareness about the risk of LSDV. The department has scheduled a series of workshops for industry on the National LSD Action Plan in June and July 2022.

The Inspector-General is aware of feedback that industry representatives have provided to the department on specific aspects of the import process. However, the Inspector-General is not aware of any significant industry concerns about the potential import of LSDV into Australia to the ACDP, Geelong facility, including ability to effectively mitigate associated risks.

The Inspector-General notes that industry consultation activities have been completed, and are planned, for key stakeholder industry organisations, regarding both the LSD threat to Australia, the national response to this threat and the potential LSDV import to the ACDP.

2. Policy approval for LSDV import

2.1 Government policy decision in place to support potential LSDV import

Australian animal biosecurity experts have been monitoring the international distribution of LSD and its threat to Australia for many years. Historically, LSD was not seen as a threat to Australia given it had not left Africa and the role of vectors in the spread of LSD was not well understood. Hence, there has been no demand for consideration by successive Australian governments of the need to import LSDV to the ACDP (formally known as the Australian Animal Health Laboratory (AAHL)) in the 40 years since its establishment.

In 1988, the Armstrong review did not recommend virulent sheep and goat pox viruses be approved for importation given the lack of risk of disease spread but was divided on whether attenuated strains of virus should be imported for future research (Committee to Review the AAHL Requirements for Exotic Pathogens, 1988). AAHL (now known as ACDP) did not request that the review committee evaluate the import of Capripoxviruses for diagnostic test development.

A microorganisms working group was formed under the then VetCom (now AHC) to assess requests for the import of pathogens of concern. In 2001 the group noted that it had not considered the import of capripoxvirus due to lack of both an import application and industry support for importation.

The threat posed to Australia from LSD has escalated significantly in recent years, which means that Australia's policy position regarding LSD preparedness must be reconsidered.

On 8 April 2022, the former Australian Government Minister for Agriculture announced agreement to the importation of live LSDV into the ACDP facility only, subject to risk assessments and regulatory approvals by the department (Littleproud, 2022).

The Inspector-General notes that this policy change enabled the department to commence the risk assessment for the importation of live LSDV to the ACDP and development of import conditions to manage the biosecurity risk under the Biosecurity Act.

The Inspector-General notes the policy context that prevailed for LSD over many years and the changed circumstances that caused the Australian Government to provide policy support for the department to commence the risk assessment for the importation of live LSDV to the ACDP.

3. Department's technical and regulatory expertise for disease agent risk assessment

The department has significant experience in conducting comprehensive risk assessments to manage a wide range of animal pathogens while permitting their handling and use in Australia. Risk analyses conducted by the department are consistent with Australia's international treaty rights and obligations, including those under the World Trade Organization (WTO) Agreement on the Application of Sanitary and Phytosanitary Measures (SPS Agreement) and WOA. Risk analyses establish the least trade-restrictive measures that meet Australia's ALOP.

3.1 Technical knowledge on Australian research on exotic animal diseases

All staff working in the Biosecurity Animal Division must hold a tertiary degree in a relevant scientific field. This gives staff members the baseline scientific knowledge, in addition to critical thinking skills developed during their studies.

Upon commencement, all staff receive extensive training in the assessment of biosecurity risk for a range of biological commodities imported for laboratory use, including microorganisms and infectious agents. Delivery of these face-to-face training sessions is recorded in a 'Newstarter Training Plan' document for each assessor. The plan includes information on who delivered the training and date of delivery. Staff working in positions that require them to make decisions under the Biosecurity Act (grant, vary or suspend permits) also undergo training and competency assessment.

In addition to the department's role in funding and regulating research on exotic animal diseases, the department also engages extensively with other regulators and departments and with state and territory governments with roles in either regulating or funding research and provides expert input into these processes as required. Recent examples of this engagement include the Office of the Gene Technology Regulator (OGTR) assessment of the clinical trial of a genetically modified alphavirus for treatment of cancer involving an exotic animal disease agent (Getah virus) (OGTR, 2021) and the National Health and Medical Research Council (NHMRC) review of all infectious disease research funded or performed by the Australian Government, including with exotic animal diseases that may have included gain-of-function of concern for the last 10 years (NHMRC, 2022).

Through its international engagement through the WOA, national engagement of all of Australia's CVOs through AHC, and ongoing cooperation with the ACDP, the department is well connected with animal health research organisations and exotic animal disease research specialists.

The Inspector-General notes that the department is well connected (both directly and indirectly) with technical specialists in exotic animal disease research, diagnostic techniques and disease control and eradication. It is well placed and active in maintaining contemporary knowledge in LSDV and related issues.

3.2 International animal biosecurity science and risk assessment network

Importation of infectious agents may be permitted under specific circumstances. The direct importation of an infectious agent represents a 100% likelihood of entry of the agent into Australia. Before the import of any infectious agent is permitted, a risk assessment of the biosecurity risks posed by microorganisms and infectious agents must be carried out. This assessment will determine the potential consequences and the appropriate risk management to prevent the establishment of the agent in Australia, in accordance with Australia's ALOP.

The department has vast experience in undertaking risk assessments of commodities which may pose a significant animal biosecurity risk to Australia. Since 2000 the department has completed 43 import risk analyses of commodities and has announced that it is undertaking 9 further reviews (DAWE, 2022f).

The department also undertakes regular assessments of the biosecurity risks posed by microorganisms and infectious agents of all levels of biosecurity risk, from endemic soil microorganisms through to exotic infectious agents which cause significant diseases of animals. These risk assessments of the importation of exotic infectious agents are captured in the following documents:

- *Policy and requirements for the importation of live and novel veterinary bulk and finished vaccines* (AQIS, 1999)
- *Second edition – Review of published tests to detect pathogens in veterinary vaccines intended for importation into Australia* (DAFF, 2013)
- *Biosecurity Advice 2012/21 – Guidelines for managing the risk of transmitting transmissible spongiform encephalopathies (TSEs) via veterinary vaccines and other in vivo veterinary products* (DAFF, 2012)
- *Assessment of genetic recombination and re-assortment of imported veterinary vaccines* (DAWR, 2016b)
- *Pathogens of animal biosecurity concern for biological products* (DAWE, 2020a).

Credibility of the department's risk assessment process is demonstrated by the close alignment of the department's risk assessment model with international best-practice frameworks. The department's risk assessment framework closely aligns with the generic framework put forward by the FAO in *An overview and framework manual for biosecurity risk analysis* (FAO, 2007). Specifically in this case, the department's risk assessment was conducted using principles set out in the *'Risk assessment' module of the World Health Organization Laboratory biosafety manual, fourth edition* (WHO, 2020). This was used as the framework for the assessment of potential pathways for escape of LSDV from biosecurity control (DAWE, 2022b).

The Centre of Excellence for Biosecurity Risk Analysis (CEBRA) supports the biosecurity activities of the department and the New Zealand Ministry for Primary Industries (MPI) by providing advice, analyses and evidence-based tools to improve Australia and New Zealand's biosecurity systems. The expert biosecurity risk analysis and advice provided by CEBRA ensures world-class research underpins the biosecurity regulatory standards, procedures and tools used by the department and the MPI.

The Inspector-General notes that the department is well connected and credentialed in infectious animal disease science and risk assessment. The department is very well equipped to conduct the risk assessment for the import of LSDV to the ACDP and related science and regulation-based functions.

3.3 International biological agent transport and import expertise

The department is knowledgeable on the international standards relating to the transport and import of biological agents. The transport of Security Sensitive Biological Agents (SSBAs) by road and rail is covered by the Australian Dangerous Goods Code (NTC, 2020). The transport of SSBAs by air is covered by the Civil Aviation Safety Regulations 1998. The Civil Aviation Safety Regulations permit transport of SSBAs by air consistent with the International Air Transport Association (IATA) (IATA, 2021a).

As LSDV is an infectious substance Category A, Division 6.2, UN 2900 agent, it is required to be packaged according to requirements set out in both the Australian Dangerous Goods Code and IATA Packing Instruction 620 (IATA, 2021b). The requirements include the need to ensure that packages are prepared in such a manner that they arrive at their destination in good condition and present no hazard to persons or animals during transport. They must also be contained within primary and secondary leakproof receptacles, with sufficient absorbent material in between and a rigid outer packaging.

To determine whether the import of a microorganism or infectious agent is permitted, the department undertakes a risk assessment. The assessment determines the potential consequences and the appropriate risk management to prevent the establishment of the agent in Australia, in accordance with Australia's ALOP. The risk assessment process includes considerations of:

- whether the infectious agent is endemic or exotic to Australia
- biological factors
- epidemiology
- pathogenicity
- any modifications, either through genetic manipulation or otherwise
- where available, its classification by other agencies, groups or standards.

Risk management measures are established and may include end-use restriction, biosecurity and biosafety containment, and restriction of the organism to a specific institution.

The department has an extensive track record in assessing import applications for biological agents. The following steps must be completed before an infectious agent is permitted to be imported into Australia:

1. The applicant applies to the department to import an infectious agent.
2. For infectious agents which the department has not previously assessed, importation is considered on a case-by-case basis, following established procedures for these assessments.
3. Where additional risk management (over and above standard containment) is determined to be required to manage potentially significant pathogens (such as LSDV), the department conducts a specific risk assessment of the laboratory facility to obtain adequate assurance that the biosecurity risks can be managed.
4. For agents the department considers significant exotic animal pathogens or pests,

the department consults with states and territories through the AHC as well as environmental experts within the department. Where required, the department also consults with industry and subject matter experts on the risk classification of the organism and the effectiveness of the proposed risk management.

5. Once effective biosecurity risk management (protocols and recommended guidelines) is determined, an import permit application can be assessed. An import permit application involves the assessment of a range of factors that go to a prospective importer's ability and capacity to safely manage the specific agent to be imported.
6. An import permit may be granted if the applicant is able to satisfy the delegate that they can meet all import conditions that may be applied.
7. The importer provides ongoing assurance that they continue to adhere to the appropriate risk management set in the import permit conditions and any regulatory requirements of the relevant approved arrangement.
8. The department conducts ongoing verification to ensure adherence to the import conditions, including document assessment for each imported consignment, audits where containment within an approved arrangement is required, and the provision of records.

The Inspector-General notes that the department's considerable technical knowledge and scientific expertise is applied to assessing all relevant aspects of LSDV importation, including logistics and transport security, and determining appropriate import conditions for live LSDV.

3.4 Effective regulatory and technical partnering with CSIRO

The department has a long history of working closely with CSIRO and specifically with the ACDP. The department continues to cooperate closely with CSIRO in a range of relevant areas.

The department's relationship with the ACDP includes the provision of funding for core activities, membership on the ACDP Security Assessment Group (ASAG) (through the ACVO), joint project work on diagnostics and preparedness activities in Australia and with near neighbours, and development and delivery of regulatory controls.

The department's demonstrated working relationship with the ACDP delivers a high level of understanding of the department's regulatory and technical requirements by the ACDP and high level of assurance of the ACDP's capability. The department and the ACDP operate under a similar understanding of biosecurity risk management and recognize the importance of their collaborative partnership in resolving issues.

This includes the ACDP's collaboration with the department for activities conducted under the Biosecurity Act. The laboratory suites within the ACDP secure area fall under an approved arrangement class 5.3 biosecurity containment level 3 (BC3) facility. The department's representatives undertake regulatory inspections to ensure compliance with requirements of BC3 laboratories.

The Inspector-General notes that the department has an appropriately effective working relationship with the ACDP (and more broadly with CSIRO). It is a robust relationship with appropriately strong focus on excellence in infectious disease science, infectious agent security and contributions to improving Australia's biosecurity status.

3.5 Track record of effective import permit assessment and regulation for disease agents

Teams responsible for the assessment of permit applications for the import of disease agents and associated decision-making have well-established processes, procedures and supporting materials in place.

A suite of documents, comprising numerous published documents and other resources, is utilised by staff routinely to assess permit applications for disease agents. It includes:

- *Pathogens of animal biosecurity concern for biological products* (DAWE, 2020a)
- *Listed Human Diseases* (DoH, 2020a)
- *Security Sensitive Biological Agents* (DoH, 2020b).

The teams routinely assess a broad range of commodities associated with microorganisms and infectious agents as part of business-as-usual activities, including but not limited to:

- infected or potentially infected animal and human fluids and tissues
- antibodies and antisera
- genetic material, including genetic expression systems
- diagnostic and molecular test kits
- goods which may be contaminated with infectious agents, such as culture media, environmental samples, cell lines and laboratory reagents
- derivatives of infectious agents, including proteins, peptides, lipids and carbohydrates.

Assessing the biosecurity risk of importing LSDV to the ACDP draws on the department's significant prior experience working with the ACDP and cooperation with other regulatory agencies that also deal with the ACDP.

The ACDP currently holds several permits for the import of a broad range of infectious agents and related material. The assessment of these import permits considered the risk management capabilities of the ACDP and the need for it to be able to promptly respond to novel and emerging threats.

The Inspector-General notes that the department has a very strong track record of import risk assessment, import permit issue and compliance management for imports of infectious agents for secure research and testing.

4. Basis for import permit approval

4.1 ACDP is a capable LSDV recipient

The ACDP is one of the world's most advanced biocontainment laboratories. Its biosecurity and biosafety are assured by means of a comprehensive system of engineering controls, with multiple redundancies to ensure containment cannot be compromised and the continuity of operations (CSIRO, 2022). The 40-year-old purpose designed and built ACDP facility was established to provide the highest levels of risk management for infectious disease agents while permitting their handling in Australia.

The ACDP's facility build was informed by a comprehensive review of global facilities and best practice at the time and is updated where possible with contemporary technology and practices. The facility has served Australia well and is held in high regard by the international biocontainment community. The ACDP has received upgrades to critical containment systems and operates a continuous improvement management system to identify and respond to opportunities for specified improvements.

The ACDP is part of an international network of high-containment laboratories sharing and applying best practices as a means of assuring the safety of staff, people and animals. Network partners include peer facilities at high-biocontainment levels working in Canada, Germany, New Zealand, United Kingdom and United States.

On 26 May 2022, the Inspector-General had an opportunity to visit the ACDP, Geelong facility. Biosecurity Animal managers from the department accompanied the Inspector-General on the visit. The Inspector-General was briefed about the ACDP's risk management strategy for importation, holding and handling of LSDV. The Inspector-General was able to view first-hand the comprehensive scheduled replacement and maintenance program for all critical ACDP machinery, technology and infrastructure that maintains the security and functionality of the ACDP at or above its design standards.

The Inspector-General's visit to the ACDP facility included:

- detailed briefings and discussion with the ACDP Director, Deputy Director, Biorisk Manager and research and diagnostic specialists regarding the procurement, transport, receipt, research and security arrangements proposed for LSDV; and the comprehensive regulatory arrangements and risk mitigation measures in place for the ACDP
- a briefing on the ACDP's vital international collaborations with Europe, North America and Asia

4. Basis for import permit approval

- a detailed tour of the accessions processes, diagnostic capability, biosafety and security procedures and the secure facilities, including the large animal facility; biosecurity containment level 4 (BC4) and physical containment level 4 (PC4); BC3 and PC3; and BC2 and PC2
- a detailed tour and briefing by the senior engineer on the comprehensive engineering and maintenance arrangements in place to ensure permanent biosafety and security for the ACDP facility.

An important discussion was the consideration of the relative specific and joint risk (individual, community, livestock) assessed for pathogens that are securely stored and subject to research within the ACDP. The ACDP has been safely and securely handling a number of pathogens that are rated higher than LSDV for one or more risk groupings – including classical swine fever, African swine fever, Ebola, Nipah and Hendra viruses.

The ACDP has its own internal risk assessment process, handled by the ASAG, which consists of key stakeholders (including the department, human health and livestock industry members) and scientific and technical experts. The ASAG provides ‘independent’ expert review of elements affecting the operations of the ACDP and advises CSIRO’s senior executive(s) of any areas of concern or risk. The scope of ASAG review includes:

- incident reports and corrective actions relating to biocontainment, biosafety and biosecurity
- structure, plant, equipment and operating procedures relating to the facility’s biocontainment
- biorisk management procedures and processes for instruction and control of personnel which may impact on biosafety, biosecurity or biocontainment
- any other matters relating to biosafety, biosecurity and biocontainment.

A comprehensive risk assessment is carried out for every pathogen held in the facility using international norms. Risk assessments also assess the risk posed by specific procedures. Biological safety cabinets (BSC) within secure laboratories provide an additional layer of personnel and scientific product protection and are required for manipulations of all infectious materials at the ACDP facility.

The visit and detailed tour of the ACDP facility raised no concerns for the Inspector-General about the proposed import of LSDV into the ACDP facility.

The Inspector-General notes that the department is satisfied that the ACDP facility is a capable LSDV recipient.

4.2 Relevant regulations are in place for import, transport, storage and use and safe disposal of LSDV by the ACDP

The department approves commercial, private and government sites for the purposes of holding certain types of material subject to biosecurity control. To gain this approval there are both containment and procedural requirements that must be met in the case of plant, animal, aquatic, microbiological and invertebrate research facilities.

The ACDP secure area is registered as an approved arrangement BC3 facility with the department; as a PC3 facility with the OGTR. ACDP is also compliant with the SSBA standards which are overseen by the Department of Health and Aged Care (DoHAC). As such, many of the relevant regulations for transport, storage, use and safe disposal of LSDV by the ACDP are provided by the approved arrangements requirements (DAWR,

2016c; DAWR, 2016d), the OGTR *Guidelines for certification of a physical containment level 3 laboratory* (OGTR, 2012) and the *Security Sensitive Biological Agent (SSBA) Standards* (DoHA, 2013).

The ACDP also has additional engineering and process requirements in place that exceed the level of risk management required for an approved arrangement BC3 facility or OGTR PC3 facility.

The ACDP also conducts work with genetically modified organisms (GMOs). Both facility certifications and project licences are held from the OGTR in support of this work. The OGTR within the DoHAC has the responsibility of implementing the Gene Technology Act 2000. The BC3 requirements specified by the department and PC3 requirements specified by OGTR are closely aligned, but each are considered separately by their auditing teams.

ASAG is responsible for independent oversight and scrutiny of the continued operation of the facility, considering the risks of proposed scientific work, maintenance activities and procedural practices implemented. ASAG is charged with monitoring and reporting biannually on the ACDP's biosecurity to CSIRO's executive team.

All regulatory agencies are responsible for regularly auditing the ACDP for regulatory compliance to ensure the safety, security and accountability of pathogens held by the ACDP facility.

The Inspector-General has also reviewed documentation related to the ACDP's accreditation to ISO14001 for environmental management and ISO9001 for compliance from the National Association of Testing Authorities (NATA).

The Inspector-General notes that the department is satisfied that the ACDP has appropriate regulations in place for the import, transport, storage, use and safe disposal of LSDV. The relevant regulations for import of LSDV, including the requirement for packaging according to IATA Packing Instruction 620, will be included as specific requirements in the import permit.

The Inspector-General notes that relevant regulations and regulatory oversight by the department are in place for all aspects of ACDP intended import, storage, use and safe disposal of LSDV. The Inspector-General makes no observation regarding the adequacy of regulatory compliance activity by other regulatory agencies relevant to the ACDP.

4.3 LSDV is an acceptable risk for use at the ACDP

The Inspector-General notes that the department considers that LSDV does not pose an unacceptable biosecurity risk for use at the ACDP.

As a capripoxvirus, LSDV has a very limited host range that does not include humans. It is primarily transmitted mechanically by insect vectors, including biting flies, midges and mosquitoes. Opportunities for it to find a suitable host and be transmitted while in use at the ACDP are highly limited. LSDV is expected to be less sensitive to organic solvents and disinfectants when compared with other enveloped viruses due to the low lipid content of the poxvirus envelope. However, it is very easily inactivated using moist heat.

The engineering and process controls in place at the ACDP are sufficient to mitigate the risk of LSDV unintentionally being released from containment at the ACDP. The engineering controls include air locks into the secure area and between suites within

the secure area; double high-efficiency particulate air (HEPA) filtration of exhaust air from BC3 areas to manage the risk of aerosols; extensive liquid effluent treatment systems with multiple control points; and a central monitoring system that oversees all equipment and processes, providing early detection of any irregularities or malfunctions. The process controls include the requirement to shower out of the secure area leaving all personal protective equipment (PPE) inside the secure area; enhanced waste management measures; annual staff competency assessments; and oversight of operations by the Biorisk Management Group.

The Inspector-General notes the department's conclusion that LSDV is an acceptable risk for use at the ACDP and acknowledges that release of LSDV from containment at the ACDP would require multiple process or engineering failures to occur concurrently.

4.4 LSDV is coming from a reputable source capable of providing pure LSDV samples

The Inspector-General notes that ACDP's network partners include peer facilities at high-biocontainment levels working in Canada, Germany, New Zealand, United Kingdom and United States.

The department has assured the Inspector-General that LSDV samples will be sourced from credible reference laboratories or established bio-banks (such as European Virus Archive – Global), and LSDV supplied to the ACDP will be characterised and verified for identity through full or partial genome sequencing prior to shipping.

For foot and mouth disease virus (FMDV) handling institutes of acceptable international standing in terms of microbiological and management practices, a copy of their standard innocuity testing protocol and a certification of freedom from FMDV signed by a senior scientist will be required for the ACDP to consider importation (DAWE, 2022b).

Pre-shipment innocuity testing will be undertaken at the source laboratory to confirm that there has been no cross-contamination of the LSDV samples with another agent during its preparation. Post-arrival innocuity testing will also be undertaken at the ACDP to ensure imported LSDV is free from extraneous agents (DAWE, 2022b).

The Inspector-General notes that the ACDP will obtain pure LSDV from a reputable source. The department will provide regulatory oversight for this stage as part of the import permit approval.

4.5 Biological samples logistics, security and safety risks can be effectively mitigated

For the import of LSDV to the ACDP facility, there are specific requirements on the import permit to manage the risks associated with improper packaging and inappropriate sourcing of LSDV. The ACDP will also follow the requirements described by the SSBA standards.

The Inspector-General has been briefed and is satisfied that requirements are in place at the ACDP facility for the transport of an LSDV sample as a Category A, Division 6.2, UN 2900 infectious substance, Dangerous Good. The sample will be packaged and shipped in accordance with Civil Aviation Safety Regulations 1998 and the IATA Packing Instruction 620.

The packaging for the LSDV sample will apply the 3-barrier containment method. This will consist of the inner packaging comprising the leakproof primary receptacle;

a leakproof secondary container; and absorbent material, between the primary and secondary containers, in sufficient quantity to absorb the entire contents of the primary container.

The ACDP will confirm with submitters and couriers that they will follow Infectious Substances Shipping Guidelines compliance for live virus shipments. Shipment of live virus will be conducted in accordance with international regulations for the transport of dangerous goods. This process establishes contact with the sending organisation and sets out key steps, to ensure there are clear expectations of shipment plan and anticipated arrival. These guidelines include specific training procedures for facility personnel involved in the process.

The LSDV sample will be transported by a licensed courier service deemed suitable and competent for transport of LSDV. The courier service will be familiar to the ACDP facility and have verified and demonstrated credentials to serve in this capacity.

For the receipt of LSDV, the ACDP must provide written confirmation of willingness to accept the material and must be notified of the expected arrival time. There are reporting requirements for the successful or unsuccessful transfer of LSDV, including that the DoHAC and law enforcement agencies must be notified if the LSDV does not arrive as expected.

The Inspector-General notes the import risk assessment and approval process will determine strict measures and detailed procedures to ensure that logistics, security and safety risks for LSDV import to the ACDP can be effectively mitigated.

4.6 ACDP receipt and security processes for LSDV meet required standards

The Inspector-General notes that requirements are in place at the ACDP to ensure person-to-person transfer occurs for LSDV. Procedures are in place for 24-hour receipt of deliveries, and LSDV must be delivered directly between couriers, receipt personnel and accession personnel.

No biologically sealed shipping packaging will be opened until it has been passed into the ACDP's secure area. Accessions personnel are appropriately trained and will arrange delivery of the LSDV package to the appropriate secure laboratory.

All personnel that will handle LSDV are required to be authorised. ACDP access controls include highly specific security steps.

Approved formal storage methods must be followed for LSDV; the inventory will be routinely checked, with spot checks carried out.

The designated Responsible Officer has responsibility to ensure all work related to LSDV will be conducted according to established policies, SOPs, relevant SSBA standards and regulations, and that all LSDV risks have been addressed.

The Inspector-General notes the strict standards and detailed procedures in place to ensure safe and secure receipt and handling of LSDV within the ACDP, Geelong facility.

5. Incident response arrangements in place

5.1 Incident response arrangements for Melbourne Airport, transport, and ACDP Geelong

The department has in place several mechanisms to respond to a biosecurity incident. The mechanism used will depend on the situation. In the event of a biosecurity incident, the department would also draw upon its own expertise (and other Australian experts where required), depending on the type of risk posed.

In the case of LSDV import, the department has ensured that additional controls are in place where routine mechanisms may not be sufficient.

Identification and notification of an incident are the crucial first steps in any incident response. All biosecurity officers, biosecurity industry participants and persons in charge have obligations (or are required) to clearly identify, respond to and notify the correct people when an incident occurs.

Where a biosecurity officer (or inspector) has been made aware of a high-risk incident, they would refer to the Managing Hazardous Goods work instruction (DAWR, 2018). This work instruction outlines the process for inspection and incident management, spillage, and exposure to identified and unidentified biological materials. In addition, the *Work instruction: International mail – dealing with hazardous and infectious goods* provides further information on the inspection and incident management process for these goods (DAWE, 2020b).

In the event of spillage, staff are to consult with the premises representative and their supervisor, evacuate the area and complete an incident report through the department's work health and safety (WHS) reporting system. The bonded premises have their own handling procedures for identified hazardous goods and, in the event of spillage, will isolate the area until decontamination is complete.

For a higher risk incident, the Post Biosecurity Detections team (PBD) would be involved in the management. This team utilises strategies and processes highlighted within their standard business, including management as well as governance and note-taking strategies.

All relevant approved arrangement sites, such as courier depots, must have a contingency plan in place to manage unexpected events that threaten to compromise biosecurity integrity (for example, criteria 14.19 for approved arrangements class 1.2).

Amongst other conditions relating to handling of goods subject to biosecurity control, cleaning and decontamination, and compliance with import permits, there is also the requirement for persons in charge of goods relating to reportable biosecurity incidents under the Biosecurity Act.

For LSDV import, the department has recognised that additional controls should be drawn upon, or put in place, as the routine mechanisms are not designed to deal with a high-risk incident involving a virus sample. These additional controls include assessment and prescription of:

- packaging requirements (to reduce the risk of spillage)
- use of trusted couriers, who can carry LSDV (to ensure they have a transport security plan in place, are trusted to use appropriate means of transport and can understand and manage an incident)
- notification of all persons in charge regarding their obligations to contain and report reportable biosecurity incidents as well as LSDV incident reporting requirements.

The Inspector-General notes that appropriate incident response arrangements are in place for the logistics chain for each imported LSDV consignment from Melbourne Airport through to ACDP, Geelong facility.

6. Ongoing accountability

6.1 Ongoing assurance review and reporting arrangements

The department's Biosecurity Animal Division has ongoing internal assurance and verification review processes in place for the import policies and conditions that may change over time due to factors such as new scientific information or changes to disease distribution.

The department and the OGTR undertake regular audits and inspections of the ACDP to ensure compliance with approved arrangement classes 5.3 and 5.4, and PC3 requirements. These audits include onsite inspections, interviews with staff and a thorough examination of records. As part of the risk assessment covering the import of LSDV into the ACDP facility, the department considered the outcomes and recommendations of the last 2 ACDP approved arrangement audits held in March 2020 and May 2021. In accordance with the department's *Approved arrangements general policies* (DAWR, 2016c; DAWR 2016d), the ACDP has demonstrated a satisfactory level of compliance during this period, permitting them to remain at a low audit rate, with one regular audit scheduled annually.

During the risk assessment, the department identified several ACDP policies which did not appear to fully outline the ongoing assurance and verification controls in place. On 16–17 June 2022, the department undertook a verification visit to the ACDP to review those documents and assess their effectiveness. The department reviewed relevant ACDP policies, SOPs and strategies covering training (including incident management).

The department found all key SOPs and policy documents were satisfactory in providing the required level of assurance that all relevant risk mitigation measures are in place and are followed by ACDP staff.

The ACDP's containment facilities and procedures have also been assessed and found to be compliant by a department-approved third-party assessor in 2012, 2013 and 2018.

The Inspector-General notes that ongoing accountability arrangements are in place for the ACDP's compliance with the provisions of the *Biosecurity Act 2015*.

7. Conclusion

The Inspector-General has reviewed the information on all key aspects of ACDP risk management and security procedures for the receipt, storage and handling of LSDV. The Inspector-General assesses that there are effective measures in place to mitigate risks associated with the import of LSDV to the ACDP facility that will meet Australia's ALOP.

The Inspector-General has assessed all 'measures in place' (Table 1) to be 'optimal'.

8. Glossary

Term	Description
Approved Arrangement	An approved arrangement is a voluntary arrangement between a participant in the biosecurity system and the Department of Agriculture, Water and the Environment for which an approval is in force. The department sets the conditions for how biosecurity activities must be performed under an approved arrangement, which are regulated under the <i>Biosecurity Act 2015</i> .
ACDP	The CSIRO ACDP (Australian Centre for Disease Preparedness), Geelong facility, formally known as Australian Animal Health Laboratory (AAHL).
ACVO	Australian Chief Veterinary Officer
AHC	The AHC (Animal Health Committee) is the national animal biosecurity policy and decision-making forum.
ALOP	Australia's ALOP (appropriate level of protection) is defined in the <i>Biosecurity Act 2015</i> as 'a high level of sanitary and phytosanitary protection aimed at reducing biosecurity risks to a very low level, but not to zero'.
ASAG	ACDP (Australian Centre for Disease Preparedness) Security Assessment Group
APVMA	Australian Pesticides and Veterinary Medicines Authority
BC	Biosecurity containment level
BIRA guidelines	Biosecurity Import Risk Analysis Guidelines 2016
Department	Department of Agriculture, Fisheries and Forestry
DoHAC	Department of Health and Aged Care
FAO	Food and Agriculture Organization of the United Nations
IATA	International Air Transport Association
LSDV	Lumpy skin disease virus
NATA	National Association of Testing Authorities
NHS	National Health Security
OGTR	Office of the Gene Technology Regulator
PC	Physical containment level
PPE	Personal protective equipment
SOPs	Standard operating procedures

Term	Description
SPS Agreement	Provisions of the SPS Agreement (WTO Agreement on the Application of Sanitary and Phytosanitary Measures) identify the rights and obligations of WTO members in the application of sanitary or phytosanitary measures, including their 'appropriate level of protection' (ALOP).
SSBAs	Security Sensitive Biological Agents
WOAH	World Organisation for Animal Health, formally known as OIE
WTO	World Trade Organization

9. References

ALEKSANDR, K., OLGA, B., DAVID, W.B., PAVEL, P., YANA, P., SVETLANA, K., ALEXANDER, N., VLADIMIR, R., DMITRIY, L. & ALEXANDER, S. 2020. Non-vector-borne transmission of lumpy skin disease virus. *Scientific Reports*, 10(1): 1–12.

AQIS (Australian Quarantine Inspection Service) 1999. [Australian quarantine policy and requirements for the importation of live and novel veterinary bulk and finished vaccines](#). Canberra: Department of Agriculture, Water and the Environment. [Accessed 27 June 2022].

Committee to Review the Australian Animal Health Laboratory's Requirements for Exotic Pathogens, CSIRO & DPIE 1988. Report of the Committee to Review the Australian Animal Health Laboratory's Requirements for Exotic Pathogens. Canberra: Australian Government Publishing Service, cat. no. 8809168, viii, 43. ISBN 0644081147.

CSIRO Australian Centre for Disease Preparedness (ACDP) 2022. Managing biorisks at ACDP: how the Australian Centre for Disease Preparedness manages the risks associated with high consequence pathogens, while also ensuring the safety and security of staff, communities and the environment. Internal document: CSIRO Australian Centre for Disease Preparedness. [Accessed 29 June 2022].

DAFF (Department of Agriculture, Fisheries and Forestry) 2013. [Biosecurity Advice 2013/05 – Review of published tests to detect pathogens in veterinary vaccines intended for importation into Australia, Second Edition](#). Canberra: Department of Agriculture, Water and the Environment. [Accessed 27 June 2022].

DAFF (Department of Agriculture, Fisheries and Forestry) 2012. [Biosecurity Advice 2012/21 – Guidelines for managing the risk of transmitting transmissible spongiform encephalopathies \(TSEs\) via veterinary vaccines and other in vivo veterinary products](#). Canberra: Department of Agriculture, Water and the Environment. [Accessed 27 June 2022].

DAWE (Department of Agriculture, Water and the Environment) 2022a. Lumpy skin disease fact sheet: Importation of live infectious agents – Animal Division: standard process for risk assessment. Internal document: Department of Agriculture, Water and the Environment.

DAWE (Department of Agriculture, Water and the Environment) 2022b. Risk assessment for the importation of infectious lumpy skin disease virus to the Australian Centre for Disease Preparedness. Internal document: Department of Agriculture, Water and the Environment.

- DAWE (Department of Agriculture, Water and the Environment) 2022c. Draft national lumpy skin disease action plan. Internal document: Department of Agriculture, Water and the Environment.
- DAWE (Department of Agriculture, Water and the Environment) 2022d. Industry advice notice: 29-2022 – [Measures to prevent the introduction of lumpy skin disease into Australia](#). Canberra: Department of Agriculture, Water and the Environment, February 2022. [Accessed 28 June 2022].
- DAWE (Department of Agriculture, Water and the Environment) 2022e. Industry advice notice: 40-2022 – [Update to list of approved countries for bovine fluids and tissues and list of countries free of lumpy skin disease \(LSD\)](#). Canberra: Department of Agriculture, Water and the Environment, March 2022. [Accessed 28 June 2022].
- DAWE (Department of Agriculture, Water and the Environment) 2022f. [Animal import risk analyses](#). Canberra: Department of Agriculture, Water and the Environment. [Accessed 27 June 2022].
- DAWE (Department of Agriculture, Water and the Environment) 2020a. [Pathogens of animal biosecurity concern for biological products](#). Canberra: Department of Agriculture, Water and the Environment. [Accessed 27 June 2022].
- DAWE (Department of Agriculture, Water and the Environment) 2020b. Work instruction: International mail – dealing with hazardous and infectious goods. Internal document: Department of Agriculture, Water and the Environment.
- DAWR (Department of Agriculture and Water Resources) 2018. Work instruction: Managing hazardous goods. Internal document: Department of Agriculture and Water Resources.
- DAWR (Department of Agriculture and Water Resources) 2016a. [Biosecurity Import Risk Analysis Guidelines 2016: managing biosecurity risks for imports into Australia](#). Canberra: Department of Agriculture and Water Resources. [Accessed 27 June 2022].
- DAWR (Department of Agriculture and Water Resources) 2016b. [Assessment of genetic recombination and re-assortment of imported veterinary vaccines](#). Canberra: Department of Agriculture, Water and the Environment. [Accessed 27 June 2022].
- DAWR (Department of Agriculture and Water Resources) 2016c. [Approved arrangements AA 5.3 – Requirements \(AA for 5.3 – Biosecurity containment level 3 \(BC3\) Requirements prepared for the Department of Agriculture and Water Resources\)](#). Canberra: Department of Agriculture, Water and the Environment. [Accessed 29 June 2022].
- DAWR (Department of Agriculture and Water Resources) 2016d. [Approved arrangements AA 7.3 – Requirements \(AA for 7.3 – Biosecurity insectary containment level 3 Requirements prepared for the Department of Agriculture and Water Resources\)](#). Canberra: Department of Agriculture, Water and the Environment. [Accessed 29 June 2022].
- DoHAC (Department of Health and Aged Care) 2020a. [Listed Human Diseases](#). Canberra: Department of Health and Aged Care. [Accessed 27 June 2022].
- DoHAC (Department of Health and Aged Care) 2020b. [Security Sensitive Biological Agents](#). Canberra: Department of Health and Aged Care, Canberra. [Accessed 27 June 2022].
- DoHA (Department of Health and Ageing) 2013. [Security Sensitive Biological Agent \(SSBA\) Standards](#). Canberra: Department of Health and Ageing. [Accessed 29 June 2022].
- EFSA (European Food Safety Authority) PANEL ON ANIMAL HEALTH AND WELFARE (AHAW) 2015. Scientific opinion on lumpy skin disease. EFSA Journal, 13(1):3986, doi: <https://doi.org/10.2903/j.efsa.2015.3986>.

- FAO (Food and Agriculture Organisation of the United Nations) 2007. FAO biosecurity toolkit. Part 3: [An overview and framework manual for biosecurity risk analysis](#). FAO Rome.
- IATA (International Air Transport Association) 2021a. [Dangerous Goods Regulations](#). 62nd edition, International Air Transport Association.
- IATA (International Air Transport Association) 2021b. [Dangerous Goods Code and IATA Packing Instruction 620](#). International Air Transport Association.
- IGB (Inspector-General of Biosecurity) 2022. [Inspector-General of Biosecurity](#). Canberra: Inspector-General of Biosecurity, Department of Agriculture, Water and the Environment. [Accessed 28 June 2022].
- ISSIMOV, A., KUTUMBETOV, L., ORYNBAYEV, M.B., KHAIRULLIN, B., MYRZAKHMETOVA, B., SULTANKULOVA, K. & WHITE, P.J. 2020. Mechanical transmission of lumpy skin disease virus by *Stomoxys* Spp (*Stomoxys calsitrans*, *Stomoxys sitiens*, *Stomoxys indica*), Diptera: Muscidae. *Animals*, 10 (3), doi: [10.3390/ani10030477](https://doi.org/10.3390/ani10030477).
- KING, A.M., LEFKOWITZ, E., ADAMS, M.J. & CARSTENS, E.B. 2011. Virus taxonomy: ninth report of the International Committee on Taxonomy of Viruses, Elsevier Academic Press, San Diego, CA, 193–201.
- KLAUSNER, Z., FATTAL, E. & KLEMENT, E. 2017. Using synoptic systems' typical wind trajectories for the analysis of potential atmospheric long-distance dispersal of lumpy skin disease virus. *Transboundary and Emerging Diseases*, 64(2): 398–410.
- LITTLEPROUD, D. 2022. [Lumpy skin disease live samples to be imported to Australia so CSIRO can develop vaccine](#), media release, the Hon. David Littleproud MP, Minister for Agriculture, Canberra, April. [Accessed 23 June 2022].
- NAMAZI, F & KHODAKARAM TAFTI, A. 2021. Lumpy skin disease, an emerging transboundary viral disease: A review. *Journal of Veterinary Medicine and Science*, doi: <https://doi.org/10.1002/vms3.434>.
- NHMRC (National Health and Medical Research Council) 2022. [Gain-of-function research review report](#). Canberra: National Health and Medical Research Council, Department of Health. [Accessed 29 June 2022].
- NTC (National Transport Commission) 2020. [Australian Code for the Transport of Dangerous Goods by Road and Rail](#), Edition 7.7, July. [Accessed 27 June 2022].
- OGTR (Office of the Gene Technology Regulator) 2021. [Risk Assessment and Risk Management Plan \(consultation version\) for DIR 187 Clinical trial of a genetically modified alphavirus for treatment of cancer](#). Canberra: Office of the Gene Technology Regulator, Department of Health, Canberra. [Accessed 29 June 2022].
- OGTR (Office of the Gene Technology Regulator) 2012. [Guideline for certification of a physical containment level 3 laboratory, version 3.1](#). Canberra: Office of the Gene Technology Regulator, Department of Health and Ageing, Canberra. [Accessed 29 June 2022].
- OIE (World Organisation for Animal Health) 2021. Lumpy skin disease, Manual of diagnostic tests and vaccines for terrestrial animals, World Organisation for Animal Health, Paris.

SOHIER, C., HAEGEMAN, A., MOSTIN, L., DE LEEUW, I., CAMPE, W.V., DE VLEESCHAUWER, A., TUPPURAINEN, E.S.M., VAN DEN BERG, T., DE REGGE, N. & DE CLERCQ, K. 2019. Experimental evidence of mechanical lumpy skin disease virus transmission by *Stomoxys calcitrans* biting flies and *Haematopota* spp. Horseflies. *Scientific Reports*, 9 (1), 20076, [10.1038/s41598-019-56605-6](https://doi.org/10.1038/s41598-019-56605-6).

TUPPURAINEN, E., DIETZE, K., WOLFF, J., BERGMANN, H., BELTRAN-ALCRUDO, D., FAHRION, A., LAMIEN, C.E., BUSCH, F., SAUTER-LOUIS, C., CONRATHS, F.J., DE CLERCQ, K., HOFFMANN, B. & KNAUF, S. 2021. Review: vaccines and vaccination against lumpy skin disease. *Vaccines*, 9, 1136. doi: <https://doi.org/10.3390/vaccines9101136>

WHO (World Health Organization) 2020. [Risk assessment](#), World Health Organization (Laboratory biosafety manual, fourth edition and associated monographs). Geneva, Licence: CC BY-NC-SA 3.0 IGO. [Accessed 30 June 2022].

10. Appendix A: Department's consultation with Australian industry stakeholders

In May 2022, the department consulted with a range of peak industry bodies through formal letters asking for their support for the importation of LSDV into Australia. Industry sectors consulted included beef, dairy, sheep, and other national agricultural representative bodies.

The department has also provided the following additional information as attachments to the letter:

- fact sheet explaining the process to import live virus from overseas laboratories to the ACDP
- fact sheet detailing biosecurity controls in place at the ACDP
- frequently asked questions about importing live LSD virus
- LSD fact sheet which can be distributed to relevant stakeholders.

An example of the letter sent from the department to key stakeholders



Australian Government
**Department of Agriculture,
 Water and the Environment**



I write to inform you that the Department of Agriculture, Water and the Environment (department) is undertaking a risk assessment for the importation of live lumpy skin disease (LSD) virus to the high security laboratory facilities at the CSIRO's Australian Centre for Disease Preparedness (ACDP). I am seeking the view of your organisation as to whether you support the importation of live LSD virus, subject to risks being satisfactorily managed to meet Australia's appropriate level of protection (ALOP).

As you would be aware, LSD has rapidly spread through Asia, and was first reported in Indonesia in March 2022. With the disease so close to our border, the risk of an LSD incursion into Australia has significantly increased.

To ensure Australia is prepared for any further spread of LSD, there is a need to expand our capability to quickly detect and respond to the presence of LSD, should the disease be detected here. Having live LSD virus at ACDP will enable development of new diagnostic capabilities which can be deployed to states and territories (noting live virus will not be permitted outside of ACDP). This will ensure that Australia is best placed to detect the presence of LSD virus early and rapidly respond to any incursion. Moreover, this capability could assist in the control of LSD in the region which will help limit the risk to Australia.

Access to live virus will also permit rigorous testing of any potential live attenuated LSD vaccines to ensure that they are of the highest possible safety standard. To conduct this testing, we need to import live LSD virus, including candidate vaccines, into ACDP. Vaccination plays a vital role in controlling and eradicating the disease.

Access to live LSD virus can also assist with creating newer, safer LSD vaccines and improved understanding of how the virus behaves under simulated Australian conditions. Noting that new vaccine development could take several years with no guarantee of a successful outcome; identifying a suitable current LSD vaccine candidate remains the immediate priority to ensure Australia is prepared in the event of an incursion. Import of live virus would also allow research on survivability and transmission of LSD with Australian livestock. This research would only be permitted at ACDP.

I am aware there may be some concerns around the risks associated with importing live LSD virus. I would like to emphasise that should import be permitted, live LSD virus will never leave ACDP. ACDP has a long history of safely importing and holding very serious exotic and zoonotic disease agents. Import of the LSD virus to ACDP does not change Australia's disease-free status. Likewise, undertaking LSD research on live animals at ACDP will not affect Australia's animal health status.

T +61 2 6272 3933
 F +61 2 6272 5161

18 Marcus Clarke Street
 Canberra City ACT 2601

GPO Box 858
 Canberra ACT 2601

awe.gov.au
 ABN 34 190 894 983

Considerations to be taken account of in the risk assessment process will include:

- a specific risk assessment of ACDP's processes and facilities (to ensure the risk of the importation of live LSD virus can be managed appropriately) as well as establishing ongoing assurance and verification of these processes undertaken by the department. This includes regular auditing as part of an approved arrangement (AA) for ACDP
- the Department of Health risk assessments on security sensitive biological agents such as LSD virus, and the National Association of Testing Authorities assurance activities for laboratories, including ACDP
- the Office of the Gene Technology Regulator independent certification of physical containment, procedures, and practices, including within the ACDP secure area
- ongoing oversight of ACDP by the ACDP Security Assessment Group.

As an additional level of assurance, the Inspector General of Biosecurity will review the proposed import process and compliance controls before any import of live LSD virus.

The department understands that peak bodies will need time to consult with their members, state and territory and affiliate-based organisations about this request. To assist with consultation, the following resources are attached for distribution:

- a fact sheet explaining the process to import live virus from overseas laboratories to ACDP
- a fact sheet detailing biosecurity controls in place at ACDP
- frequently asked questions about importing live LSD virus
- an LSD fact sheet which can be distributed to members.

I would greatly appreciate your organisation's view on the proposal to import live LSD virus into ACDP. Please provide your response to lumpyskindiseasecoord@agriculture.gov.au by 31 May 2022. If you have questions or would like to discuss, please contact Tim Brinkley on 026272 3244 or e-mail lumpyskindiseasecoord@agriculture.gov.au. In addition, to facilitate your consideration a virtual Q & A session will be held 1pm AEST on 16 May 2022 where the department and ACDP will be available to answer questions. An invitation to this session will be sent to you shortly.

Yours sincerely

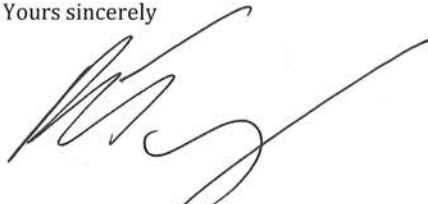

Andrew Tongue **ESM**
Deputy Secretary
Biosecurity and Compliance Group
Department of Agriculture, Water and the Environment

3 May 2022

Attachment A – Live virus import process from overseas laboratories to ACDP

Attachment B – Biosecurity controls and protocols at ACDP

Attachment C – Frequently asked questions about importing live LSD virus

Attachment D – LSD fact sheet

Attachment A: Live virus import from overseas laboratory to ACDP

ATTACHMENT A



Transport of Lumpy Skin Disease Virus to ACDP

Risk management considerations for source, transport and receipt of LSD virus at ACDP.

Live Virus From an International Source

ACDP will source live Lumpy Skin Disease virus isolates from a peer facility of similar standing. Confirmation of virus provenance and adventitious agent testing will be sought in advance, and ACDP will expect a comprehensive package of such information to accompany the shipments. Repeat adventitious agent testing will be performed at ACDP upon receipt.

IATA Packaging Requirements

ACDP will confirm with submitters and couriers that they will follow Infectious Substances Shipping Guidelines compliance for live virus shipments. These guidelines include specific training procedures for facility personnel involved in the process.

Packaging instruction 620 for shipment of live LSDv utilises a three-barrier containment method with the inner packaging comprising of the leakproof primary receptacle, a leakproof secondary container and absorbent material in sufficient

quantity to absorb the entire contents of the primary container located between the primary and secondary containers. The primary receptacle or secondary packaging must be capable of withstanding, without leakage, an internal pressure producing a pressure differential of not less than 95kPa and temperature in the range of -40°C to 55°C.

Transport of the package will be done using the licensed courier services familiar to ACDP that have verified (and demonstrated) their credentials to serve in this capacity.

Shipping requirement for shipment and receipt of live LSDv

Shipment of live virus will be conducted in accordance with applicable international regulations for the transport of dangerous goods. ACDP will follow the requirements described by the Australian Security Sensitive Biological Agents Standards (SSBA). This establishes contact with the sending organisation and sets out key steps, to ensure there are clear expectations of shipment plan and anticipated arrival.

- Confirmation that ACDP is prepared to receive the virus prior to shipment.
- Provision of all necessary permits and declarations to each party.
- Shipment details from sending laboratory and confirmation of dispatch.
- Confirmation of receipt back to sender including notes regarding any damage or signs of tampering to the packaging.
- Notification to government oversight bodies of package receipt

Receipt and accessioning at ACDP

Upon arrival at ACDP all paperwork will be confirmed and information entered into ACDP's tracking database. The biologically sealed shipping packaging will not be opened until it has been passed into the ACDP Secure Area. The samples will be logged into our Laboratory Information Management System ensuring that there is a traceable record to which all derivative material can be related and stored according to strict SSBA security standards.

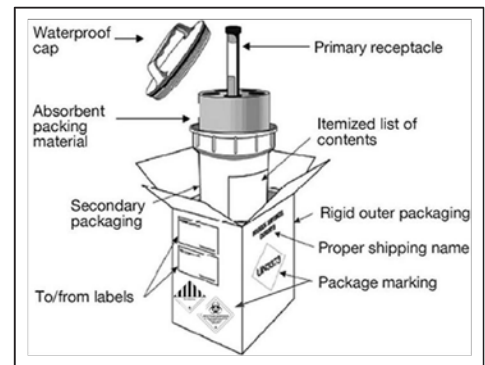

CSIRO Australia's National Science Agency

Attachment C: Frequently asked questions about importing live LSD virus

ATTACHMENT C

Importation of lumpy skin disease virus frequently asked questions

Why does Australia need to import live lumpy skin disease virus?

Importing lumpy skin disease (LSD) virus will help improve Australia's diagnostic capacity and facilitate Australia's access to safe and effective vaccines against the disease, if required. Access to the live virus will also enable Australia's top scientists to undertake research on LSD virus, which could lead to better understanding of the virus and vaccines for Australia and the region.

Diagnostics

Importing live LSD virus will improve Australia's diagnostic capacity. It will allow ACDP to develop and validate new and improved tests for LSD. ACDP will also establish proficiency testing programs using safely inactivated material, to ensure state and territory government veterinary laboratories have LSD diagnostic capacity. Any diagnostic material that leaves ACDP will never contain live LSD virus. This means Australia's laboratory testing system will be well prepared and able to respond rapidly if there is an outbreak.

Vaccines

All currently available commercial vaccines contain attenuated live LSD virus. Allowing import of the live virus will ensure Australia can test the quality and safety of internationally available LSD vaccines and then use a safe vaccine if there is an outbreak either domestically or in our near neighbours.

Ability to test samples from our near neighbours

Our near neighbours such as Timor-Leste and Papua New Guinea have limited diagnostic capacity and rely on Australia to provide laboratory support in the event of a disease outbreak. This support has previously been provided for African swine fever. In the event of an outbreak of LSD in our near neighbours, it would be vital that Australia could import animal tissues that may contain live virus to provide diagnostic support to assist with the outbreak response and limit the spread of the disease. Helping to control disease in our near neighbours is vital for Australia's efforts to keep LSD virus from Australia.

What is the process for importing the live virus?

- A risk assessment of the importation of LSD virus is being undertaken by the Department of Agriculture, Water and the Environment. The assessment will determine if there are risk management measures available to safely import the virus.
- The department will conduct a specific risk assessment of the facility at ACDP.
- The department will consult with states and territories including through the Animal Health Committee (AHC – comprises Chief Veterinary Officers from the commonwealth and states and territories) on the effectiveness of the proposed risk management.
- If it is determined that effective biosecurity risk management is possible an import permit application can be assessed.

- An import permit application involves the assessment of a range of factors including the ability and capacity to safely manage the virus. A permit will also set the specific conditions that must be complied with when importing the virus, including safe and secure transportation in accordance with recognised international standards.
- An import permit will only be granted under the *Biosecurity Act 2015* if ACDP is able to satisfy the delegate of the Director of Biosecurity that they can meet all import requirements and conditions that may be applied.
- The department will conduct ongoing assurance and verification activities with ACDP to ensure that they continue to adhere to all risk management requirements in accordance with and through the use of approved arrangement criteria, other agreements and the import conditions.

How will the risks be managed?

The department will work with ACDP to perform a specific risk assessment of the processes and facilities at ACDP to ensure that the risk of the importation of live LSD virus can be managed appropriately, to support the issuance of an import permit under the *Biosecurity Act 2015*.

An independent assurance review will also be conducted by the Inspector General of Biosecurity before the issuance of an import permit.

Only the secure facilities within ACDP with the absolute highest biosecurity controls will ever be permitted to conduct research on live LSD virus. These facilities feature many layers of containment and strict controls to prevent the release of any pathogens.

In addition to the ongoing risk management required by the department, the use of LSD virus at ACDP will be regulated through the following mechanisms.

- The Office of the Gene Technology Regulator independently certifies facilities on appropriate physical containment, procedures, and practices, including within the ACDP secure area, and conducts risk assessments where genetically modified organisms are involved.
- The Department of Health conducts risk assessments on security sensitive biological agents such as LSD virus.
- The National Association of Testing Authorities undertakes regular assurance activities for laboratories.
- There is ongoing oversight of ACDP by the ACDP Security Assessment Group. This group of technical experts provides independent advice to CSIRO senior executives on microbiological and physical security relating to the facilities and operations of ACDP.

Is there a risk of the lumpy skin disease virus escaping from a laboratory?

If the virus is imported, it will only be held at ACDP, a built for purpose high containment facility. Since it was first opened in 1985, there have been no breaches of biosecurity containment. ACDP has successfully managed the containment of many live viruses throughout this time, including OIE-listed disease agents, Hendra virus, African swine fever virus and many other significant human and animal disease agents.

Will we lose our disease-free status if Australia imports lumpy skin disease virus?

No. Australia will only lose its disease-free status if there is an outbreak of the disease in the general Australian animal population. Use of any live virus or vaccine for research (including for example if LSD virus is injected into animals) in a high containment facility such as ACDP will not affect Australia's disease-free status. ACDP has held other Nationally Notifiable and OIE-listed disease agents for many years with no effect on our disease-free status for those diseases.

How is are the risks of the importation of LSD virus managed in transport before the virus arrives at ACDP?

Please refer to **Attachment A** for a fact sheet about international movements of viruses and the extensive regulations, packaging and containment requirements for the movement of LSD virus into ACDP.

How does ACDP manage biosecurity risk?

Please refer to **Attachment B** for a fact sheet about the facility and biosecurity containment at ACDP.

Attachment D: LSD fact sheet

ATTACHMENT D

Lumpy skin disease fact sheet

What is lumpy skin disease?

Lumpy skin disease (LSD) is a highly infectious disease of cattle and water buffalo that does not affect other livestock or humans. The disease is caused by a virus like sheep pox and goat pox and is mostly transmitted by biting insects.

Why is the disease a concern?

The global distribution of LSD is changing. Since 2019 the disease has spread through China and Southeast Asia, and in 2021 the disease was confirmed in Vietnam, Thailand and Malaysia. In March 2022 it was officially reported by Indonesia on the island of Sumatra.

If LSD were to occur in Australia, this would cause significant production costs to beef, water buffalo, and dairy cattle industries. In addition, there could be substantial effects on trade if Australia was no longer recognised as being free from LSD. The cost of an LSD incursion could also see severe economic losses to Australia's meat processing sector. Eradication of the disease would also be costly and difficult.

How the disease spreads

The transmission of LSD is not completely understood. The main two routes of transmission are mechanical transmission by arthropod vectors such as mosquitoes, ticks and biting flies and the movement of infected animals. The disease can also be spread by fomites through such things as contaminated equipment and in some cases directly from animal to animal. The disease has shown an ability to establish and spread in a wide range of environmental and production systems around the world.

Signs of lumpy skin disease in animals

Signs include:

- firm, raised nodules up to 50 mm in diameter develop on the skin around the head, neck, genitals and limbs. Nodules can develop on any part of the body
- scabs develop in the centre of the nodules after which the scabs fall off, leaving large holes that may become infected
- swelling of the limbs, brisket and genitals may occur
- watering eyes
- increased nasal and salivary secretions
- some animals with the disease may be asymptomatic (have the disease but not show signs).

Vaccination

There is currently no LSD vaccine approved for use in Australia. In southern Europe vaccination with a live attenuated virus has been used to effectively control LSD outbreaks. However, in other areas vaccination has not been successful in controlling the disease. Australia will commence the consideration of commercially available vaccines for emergency use should they be needed.

Reporting

If you suspect a case of LSD, call the Emergency Animal Disease Watch Hotline (1800 675 888) immediately.

More questions?

Visit our [lumpy skin disease web page](#) and scroll to the bottom to see a list of frequently asked questions.

ATTACHMENT D



Lumpy skin disease in cattle overseas. (Photo credit: Michael Patching)



Lumpy skin disease in cattle overseas. (Photo credit: Michel Bellaiche, Kimron Veterinary Institute)

11. Agency response



ANDREW METCALFE AO
SECRETARY

21 July 2022

Mr Rob Delane
Inspector-General of Biosecurity
c/o Department of Agriculture, Fisheries and Forestry
GPO Box 858
Canberra ACT 2601

Rob

Dear Mr Delane,

Thank you for your correspondence of 8 July 2022 providing your report, *Assurance review for arrangements to import live lumpy skin disease virus to CSIRO's Australian Centre for Disease Preparedness*, for management comments on the review findings.

The Department of Agriculture, Fisheries and Forestry notes the recommendations of the report and has commenced work assessing the biosecurity import permit application for the import of lumpy skin disease virus (LSDV) to the CSIRO's Australian Centre for Disease Preparedness (ACDP). I also note and appreciate your further insights and observations on the department's approach to biosecurity risk assessment and management strategies for biological agent importation. I also note your observations regarding the biosecurity arrangements in place at the ACDP facility for the transport, receipt and secure handling of LSDV.

The department is committed to ongoing improvement and will continue to work with the ACDP to ensure the biosecurity risks of working with infectious LSDV at ACDP continue to meet Australia's Appropriate Level of Protection.

The department has assessed the report and does not consider the release of any information contained in the report to be prejudicial to the public interest.

Best wishes

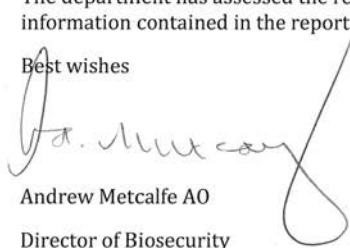
Andrew Metcalfe AO
Director of Biosecurity

T +61 2 6272 3933
F +61 2 6272 5161

18 Marcus Clarke Street
Canberra City ACT 2601

GPO Box 858
Canberra ACT 2601

agriculture.gov.au
ABN 34 190 894 983

www.igb.gov.au